



LIGHTING • FIRE & CO DETECTION



BATTERY OPERATED SMOKE DETECTOR



FEATURES

- Loud 85dB alarm
- 9v Battery included
- Insect proof
- Test button
- Low battery warning
- Easy installation

TECHNICAL INFORMATION

Scheme Rating:	F2
Detection Type:	Photoelectric Sensor
Power Source:	9v Battery
Alarm Sound Level:	85dB at 3 metres
Operating Temp:	0°C ~ 40°C
Test Button:	Yes & LED warning indicator
Mounting Plate:	Yes
Approvals:	BS EN14604:2005

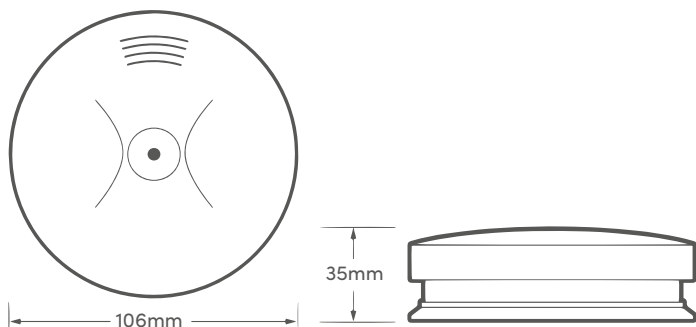

Product Code: HSA/BP



hispec.co.uk

